

## FLASHINGS - SUPER NEO-POLY®

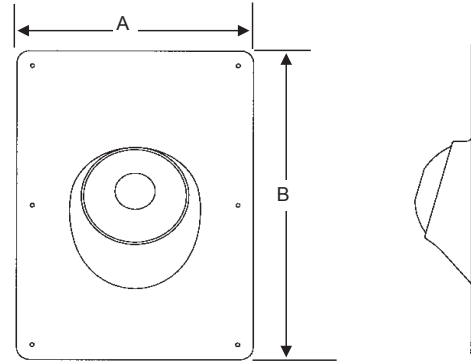
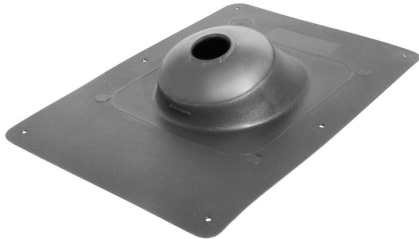

### SPECIFICATION

Furnish and install Rubber Flashing to eliminate leaks and resist extreme weather conditions.

### DESIGN FEATURES

- Eliminates leaks by incorporating a rush and seal in the flashing cone, which compresses around the pipe, making it water tight
- Resistant to ultraviolet rays, moisture, salt air corrosion and extreme weather conditions
- Self-sealing design allows for pipe expansion and contraction
- Use with ABS, PVC, galvanized and cast iron DWV pipe
- Flexible so that it conforms to roof shakes, shingles and flat tile (universal)

### COMPLIANCE/LISTINGS

- IAPMO 0956; IAPMO PS 64-2012ae1/UPC/IPC

### SPECIFICATION

- Roof Pitch: SUPER NEO-POLY® 0-51°

SUPER NEO-POLY ROOF FLASHING			
PART NUMBER	DESCRIPTION	PIPE SIZE	MSTR CTN QTY
<b>MULTI-FIT</b>			
P-7123	10-3/4" x 13-5/8"	1-1/4", 2", 3"	12

Product Submittal	
Job Name:	Date:
Part Number:	Quantity:
Architect:	
Contractor:	

Content matter is subject to change at any time. It is the user's responsibility to ensure the most updated revisions are obtained. 5/2023