

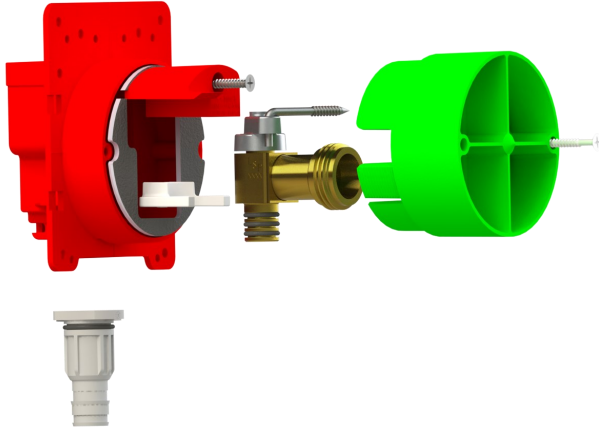

# FIRESTOP™ WASHING MACHINE PULL STOP BOX™

Specification Sheet



## DIMENSIONS

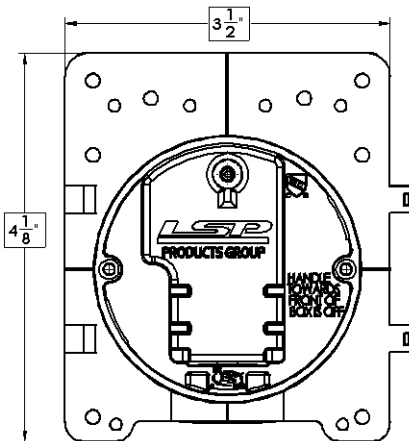
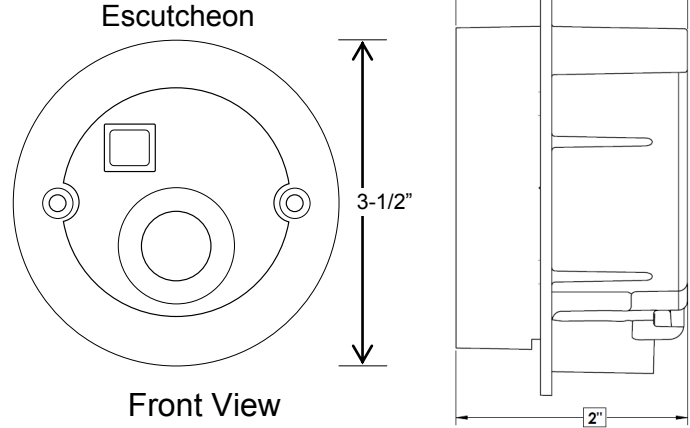

### SPECIFICATION

Furnish and install the FireStop™ Washing Machine Pull Stop Box™ outlet box as manufactured by LSP Products Group.

### DESIGN FEATURES

- **Must use metal brackets during installation**
- Patented design moves the angle-stop for washing machine water supply into the wall
- Allows angle stops to be installed during the rough-in phase and be pressure tested for reduced liability and labor
- Easy to install vertically, upside down and, horizontally
- Eliminates the need for a copper stub out
- Unique push-pull handle opens and closes the valve
- Integrated, replaceable valve has a reliable triple O-ring design inlet seal
- 5-year, limited warranty
- 1 hour and 2 hour fire rated
- Available deep faceplate accepts up to two sheets of 5/8" drywall
- Intumescent pad seals through wall penetration
- Ball valve design with Teflon seats
- 3/4" GHT outlet connection

### CAUTION

- Keep away from solvents/cements/primers
- Keep out of sun and away from common heat sources.
- If Supply line supports or clamps are necessary (as determined by state or local code), we recommend installing them no closer than 6" to the box

### OPERATING SPECIFICATION

- Working Temperature 40°F-160°F
- Working Pressure 20-125 PSI



3689 Arrowhead Drive, Carson City, NV 89706  
 Phone: (800) 854-3215 | Fax: (800) 243-1777  
 E-mail: sales@lspproducts.com | Website: www.lspproducts.com  
 Content matter is subject to change at any time. It is the user's responsibility to ensure the most updated revisions are obtained.  
 Rev 10/18

### COMPLIANCES/LISTINGS

- IAPMO listed to PS 54, File 0901
- ICC-ES Listed to PMG-1154
- Intertek/Warnock Hersey listed for 1hr and 2hr Fire Walls, WN 16958



Product Submittal	
Job Name:	
Date:	
Part Number	Quantity
Architect:	
Contractor:	



# FIRESTOP™ WASHING MACHINE PULL STOP BOX™ Specification Sheet

Part Number	Inlet Type
<b>ROUGH-IN KIT - includes box, valve, and protective cover</b>	
OBFPS-121-RK	½" Sweat Lead Free
OBFPS-122-RK	½" CPVC Lead Free
OBFPS-123-RK	½" PEX (Vanguard and Zurn) Lead Free
OBFPS-124-RK	½" Wirsbo/Uponor PEX Lead Free
OBFPS-125RK	½" Viega PureFlow PEX Lead Free
OBFPS-128RK	½" EVERLOC+ PEX Lead Free
<b>TRIM KIT - includes knob and escutcheon</b>	
OBPS-400-W*	White - Paintable - Regular Depth 1/2" to 1" Depth, Includes two screws and red clip
OBPS-400D-W*	White - Paintable - Deep Depth 1" to 1.72" Depth, Includes two screws and red clip
OBPS-400SD-W*	White - Paintable - Super Deep Depth 1.75" to 2.43" Depth, Includes two screws and red clip

\*Great for ice maker, dishwasher and washing machine Pull Stop Box™.

MATERIAL SPECIFICATIONS	
Part	Material
Valve Body, Stem	Brass
Valve Handle	Cast Aluminum
Ball	Chrome Plated Brass
O-rings	High Temperature Rubber
Box	Fire Resistant ABS
PEX Inlet Connection	Engineered Polymer PPSU
CPVC Inlet Connection	Fitting Grade CPVC
Copper Inlet Connection	ASTM B88 Copper Tube

ACCESSORIES/REPLACEMENT PARTS	
OBFD-100	Fire Rated Washing Machine Drain Box
P-06923	Escutcheon Extension - Can be used with any trim kit to cover any excessively large holes in the drywall up to 4.5" diameter hole. <b>MUST BE USED WITH AN EXISTING TRIM KIT.</b>
P-06930	Dual Escutcheon Extension - For side by side installations. Can be used with any 2 trim kits to cover any excessively large holes in the drywall up to 4.5" diameter hole. <b>MUST BE USED WITH EXISTING TRIM KITS.</b>
P-06881	3/4 GHT", 1/4 Turn Replacement Valve
OBPS-500D-W	Escutcheon depth Extension Kit, .8" additional depth for cabinet backs and/or for more than two layers of drywall
P-06926	Extension rod for PSB handle for deep installations

AUXILIARY FIXTURING	
P-1078-18	18" Straight HYCO bar
P-1078-26	26" Straight HYCO bar
P-1090	Boss Bar™ - 10" to 18" adjustable sliding bracket
P-1093	Boss Bar™ - 13" to 24" adjustable sliding bracket

Product Submittal	
Job Name:	
Date:	
Part Number	Quantity
Architect:	
Contractor:	



3689 Arrowhead Drive, Carson City, NV 89706  
 Phone: (800) 854-3215 | Fax: (800) 243-1777  
 E-mail: sales@lspproducts.com | Website: www.lspproducts.com  
 Content matter is subject to change at any time. It is the user's responsibility to ensure the most updated revisions are obtained.  
 Rev 10/18

## FIRESTOP™ WASHING MACHINE PULL STOP BOX™ Specification Sheet

### ROUGH-IN INSTALLATION INSTRUCTIONS

1. Fire rated Pull Stop Boxes are to be mounted in 5/8" Type X gypsum wallboard on each side of supporting construction. Minimum one layer wall board for one hour wall rating and minimum two layers for two hour wall rating. Wall studs can be either 20 GA galvanized steel or wood with minimum depth of 3-5/8 inch.
2. Identify the desired outlet location. Attach the supply line to the valve inlet via pipe manufactures recommended practice. (i.e. sweat for copper, solvent cement for CPVC, crimp rings for PEX). If supply line supports or clamps are necessary (as determined by state or local code), we recommend installing them no closer than 6 inches to the box.
3. FireStop™ Pull Stop Box™ may be installed individually, in pairs or three Pull Stop boxes in one stud bay all facing the same direction. Pull Stop boxes facing the other direction must be mounted in separate stud bay.
4. FireStop™ Pull Stop Box™ **must be mounted with at least two metal support brackets, one across the top and one across the bottom with two screws as shown in figure below.** Suggest using LSP's metal HYCO strap P-1078-18, P-1078-26 or Boss Bar on top P-1090 or P-1093 may be used on top.
5. The FireStop™ Pull Stop Box™ is shipped in the "Off" position. Once the box is securely attached to the wall and the supply line is properly attached no further work is necessary during the rough-in phase. The included protective cover will protect the valve during the construction process.

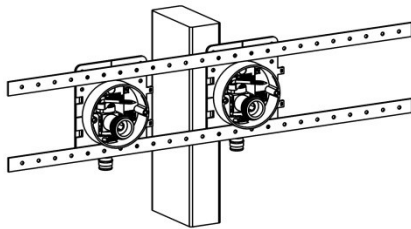

### TRIM INSTALLATION INSTRUCTIONS

1. Pull off the protective cover.
2. Line up the threaded metal arm to fit through the square hole in the escutcheon and push the escutcheon into the outlet box until it is flush with the wall while making sure to feed the threaded metal arm through the square hole.
3. Screw escutcheon in using the two supplied screws.
4. Thread the knob onto the threaded metal arm until there is interference with the escutcheon, but a minimum of four complete turns.
5. Snap "U" shaped part of the red clip onto the knob to prevent the valve from being accidentally turned on.
6. When it's time to install the supply line, simply tighten it on to the valve outlet. There is no need to remove the escutcheon.
7. When water supply is desired, pull off the red clip, push the knob towards the wall to turn the valve on, and then snap the "C" shaped part of the red clip onto the end of the handle for storage.
8. To stop the flow of water, pull the knob out.

### VALVE REPLACEMENT INSTRUCTIONS

1. Turn off water supply to building. Then, pull knob to "off" position.
2. Unscrew knob and screws. Then, pull out the escutcheon.
3. Remove the screw and valve block. Then, remove current valve and replace with a new one.
4. Secure the valve block back into place with the screw.
5. Follow steps 3-8 under **Trim Installation Instructions**.



Product Submittal	
Job Name:	
Date:	
Part Number	Quantity
Architect:	
Contractor:	