

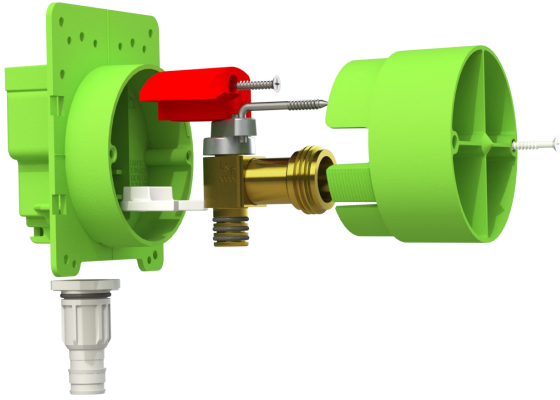

WASHING MACHINE PULL STOP BOX™

Specification Sheet



DIMENSIONS

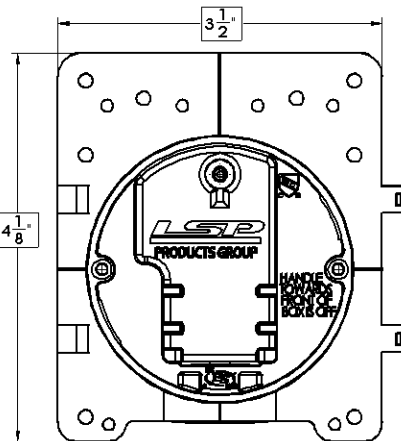
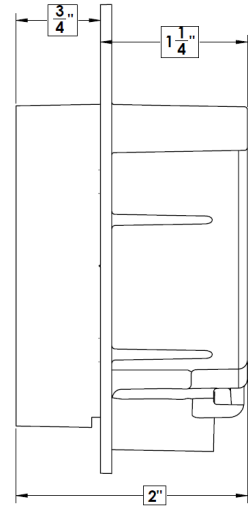
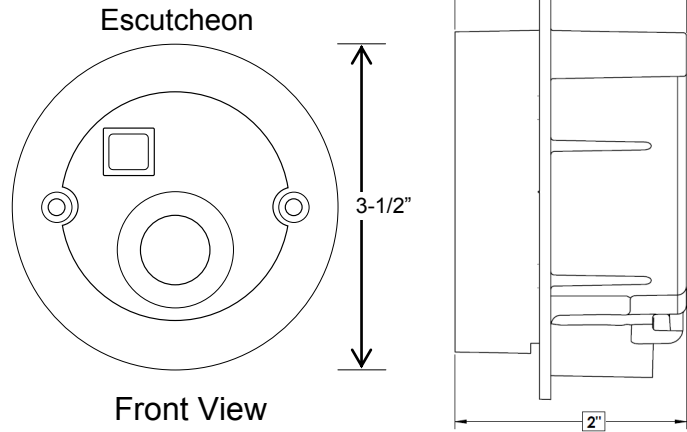

SPECIFICATION

Furnish and install the Washing Machine Pull Stop Box™ outlet box as manufactured by LSP Products Group.

DESIGN FEATURES

- Patented design moves the angle-stop for washing machine water supply into the wall
- Allows angle stops to be installed during the rough-in phase and be pressure tested for reduced liability and labor
- Easy to install vertically, upside down and, horizontally
- Eliminates the need for a copper stub out
- Unique push-pull handle opens and closes the valve
- Integrated, replaceable valve has a reliable triple O-ring design inlet seal
- 5-year, limited warranty
- Available deep faceplate accepts up to two sheets of 5/8" drywall
- Ball valve design with Teflon seats
- 3/4" GHT outlet connection

CAUTION

- Keep away from solvents/cements/primers
- Keep out of the sun

OPERATING SPECIFICATION

- Temperature: 40-180°F
- Pressure: 125 PSI max.

COMPLIANCES/LISTINGS

- IAPMO listed to ASME A112.18.1/CSA B125.1, File 4577
- IAPMO listed to PS 54, File 0901
- ICC-ES Listed to PMG-1154



3689 Arrowhead Drive, Carson City, NV 89706

Phone: (800) 854-3215 | Fax: (800) 243-1777

E-mail: sales@lspproducts.com | Website: www.lspproducts.com

Content matter is subject to change at any time. It is the user's responsibility to ensure the most updated revisions are obtained.

Product Submittal	
Job Name:	
Date:	
Part Number	Quantity
Architect:	
Contractor:	



WASHING MACHINE PULL STOP BOX™

Specification Sheet

Part Number	Inlet Type
ROUGH-IN KIT - includes box, valve, and protective cover	
OBPS-121-RK	½" Sweat
OBPS-122-RK	½" CPVC
OBPS-123-RK	½" Crimp PEX
OBPS-124-RK	½" Uponor PEX
OBPS-125-RK	½" Viega PureFlow PEX
OBPS-128-RK	½" EVERLOC+ PEX
TRIM KIT - includes knob and escutcheon	
OBPS-400-W*	White - Paintable - Regular Depth 1/2" to 1" Depth, Includes two screws and red clip
OBPS-400D-W*	White - Paintable - Deep Depth 1" to 1.72" Depth, Includes two screws and red clip
OBPS-400SD-W*	White - Paintable - Super Deep Depth 1.75" to 2.43" Depth, Includes two screws and red clip

*Great for ice maker, dishwasher and washing machine Pull Stop Box™.

MATERIAL SPECIFICATIONS	
Part	Material
Valve Body, Stem	Brass
Valve Handle	Cast Aluminum
Ball	Chrome Plated Brass
O-rings	High Temperature Rubber
Box	High Impact ABS
PEX Inlet Connection	Engineered Polymer PPSU
CPVC Inlet Connection	Fitting Grade CPVC
Copper Inlet Connection	ASTM B88 Copper Tube

ACCESSORIES/REPLACEMENT PARTS	
OBD-100	Washing Machine Drain box with optional condensate.
P-06923	Escutcheon Extension - Can be used with any trim kit to cover any excessively large holes in the drywall up to 4.5" diameter hole. MUST BE USED WITH AN EXISTING TRIM KIT.
P-06930	Dual Escutcheon Extension - For side by side installations. Can be used with any 2 trim kits to cover any excessively large holes in the drywall up to 4.5" diameter hole. MUST BE USED WITH EXISTING TRIM KITS.
P-06881	3/4" GHT, 1/4 Turn Replacement Valve
OBPS-500D-W	Escutcheon depth Extension Kit, .8" additional depth for cabinet backs and/or for more than two layers of drywall
P-06926	Extension rod for PSB handle for deep installations

AUXILIARY FIXTURING	
P-1078-18	18" Straight HYCO bar
P-1078-26	26" Straight HYCO bar
P-1090	Boss Bar™ - 10" to 18" adjustable sliding bracket
P-1093	Boss Bar™ - 13" to 24" adjustable sliding bracket

Product Submittal	
Job Name:	
Date:	
Part Number	Quantity
Architect:	
Contractor:	



3689 Arrowhead Drive, Carson City, NV 89706

Phone: (800) 854-3215 | Fax: (800) 243-1777

E-mail: sales@lspproducts.com | Website: www.lspproducts.com

Content matter is subject to change at any time. It is the user's responsibility to ensure the most updated revisions are obtained.



WASHING MACHINE PULL STOP BOX™ Specification Sheet

ROUGH-IN INSTALLATION INSTRUCTIONS

1. Identify the desired outlet location.
2. Attach the supply line to the valve inlet via pipe manufactures recommended practice. (i.e. sweat for copper, solvent cement for CPVC, crimp rings for PEX)
3. Fasten the Washing Machine Pull Stop Box™ using two screws or two nails into a stud. (Do not over tighten screws or over drive nails). Supply line pipe clamps need to be installed a minimum of 6 inches above/below Pull Stop Box™ inlet connection
4. The Washing Machine Pull Stop Box™ is shipped in the “off” position. Once the box is securely attached to the wall and the supply line is properly attached, no further work is necessary during the rough-in phase. The included protective cover provides significantly better protection of the valve/valve threads during the drywalling/construction processes.

TRIM INSTALLATION INSTRUCTIONS

1. Pull off the protective cover.
2. Line up the threaded metal arm to fit through the square hole in the escutcheon and push the escutcheon into the outlet box until it is flush with the wall while making sure to feed the threaded metal arm through the square hole.
3. Screw escutcheon in using the two supplied screws.
4. Thread the knob onto the threaded metal arm until there is interference with the escutcheon, but a minimum of four complete turns.
5. Snap “U” shaped part of the red clip onto the knob to prevent the valve from being accidentally turned on.
6. When it’s time to install the supply line, simply tighten it onto the valve outlet. There is no need to remove the escutcheon.
7. When water supply is desired, pull off the red clip, push the knob towards the wall to turn the valve on, and then snap the “C” shaped part of the red clip onto the end of the handle for storage.
8. To stop the flow of water, pull the knob out.

VALVE REPLACEMENT INSTRUCTIONS

1. Turn off water supply to building. Then, pull knob to “off” position.
2. Unscrew knob and screws. Then, pull out the escutcheon.
3. Remove the screw and valve block. Then, remove current valve and replace with a new one.
4. Secure the valve block back into place with the screw.
5. Follow steps 3-8 under **Trim Installation Instructions**.

OPERATING SPECIFICATION

- Temperature: 40-180°F
- Pressure: 125 PSI max.



3689 Arrowhead Drive, Carson City, NV 89706

Phone: (800) 854-3215 | Fax: (800) 243-1777

E-mail: sales@lspproducts.com | Website: www.lspproducts.com

Content matter is subject to change at any time. It is the user’s responsibility to ensure the most updated revisions are obtained.

SP/SH (10-18) Rev 4

Product Submittal	
Job Name:	
Date:	
Part Number	Quantity
Architect:	
Contractor:	