

THE POWER BOX

FIRESTOP™ DUAL DRAIN

WASHING MACHINE OUTLET BOX

Powerbox is a versatile fire-rated outlet box with right-justified, top-mounted CPVC valves and the choice of left, right, or center drain. Pair with the newly designed condensate funnel, with built in air gap, to utilize the left-justified condensate knockouts for 3/4" and 1" IPS piping.

DESIGN FEATURES

- 1hr and 2hr fire rated
- Proven design with fire rating
- Selectable drain orientations
- Integrated knockout test cap
- Deep faceplate accepts up to two sheets of 5/8" drywall
- Intumescent pad for fire protection
- Box constructed of fire resistant PVC

COMPLIANCES/LISTINGS

- Warnock Hersey listed 1hr and 2hr:
ASTM E814, CAN/ULC S115, IAPMO/UPC Certified 0901
- Valve also meets or exceeds:
ASME A112.18.1, NSF Standard 61

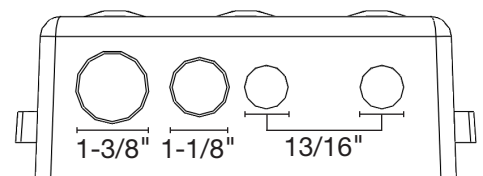
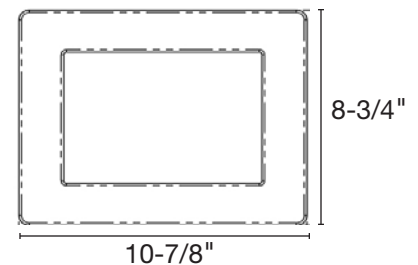
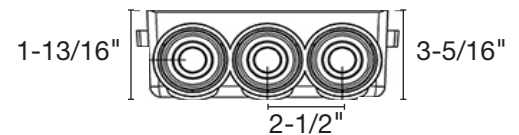
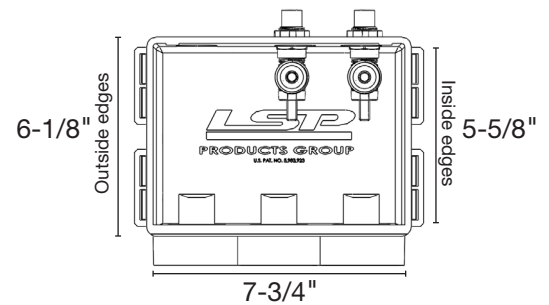

Part Number	Description	Master Carton Qty
OBFS-2021-TOP-RK	White, Fire Rated, Top mounted CPVC valves (non Hammer Arrestor)	10
P-00213	White Faceplates	55
P-00221	Condensate Funnel w/ Air Gap	1

* Add "-T" to the end of these part numbers for Tract Pack (faceplates packaged separately)

* Add "-TOP" to the end of the part number for Top Mounted valves

Product Submittal	
Job Name:	Date:
Part Number:	Quantity:
Architect:	
Contractor:	

Content matter is subject to change at any time. It is the user's responsibility to ensure the most updated revisions are obtained. 5/2023